

OPERATIONAL AND SCIENTIFIC NOTES

AN ELECTRICALLY CONTROLLED PESTICIDE AGITATION SYSTEM FOR ROTARY-WINGED AIRCRAFT MOUNTED SPRAYERS¹

W. HETRICK, T. KEIM, J. KREYLING, E. SUTTON AND T. W. MILLER, JR.

Lee County Mosquito Control District, P.O. Box 06005, Fort Myers, FL 33906

Agitation of formulations of *Bacillus thuringiensis* var. *israelensis* (B.t.i.) and Arosurf[®]MSF during aerial spray application by rotary-winged aircraft is required to prevent sprayer clogging and ensure consistent application rates. The objective of this developmental effort was to design and fabricate a cost-effective, electrically

ically for a Bell UH-1 helicopter. Mechanical agitation was selected since our previous tests indicated that it was superior to jet agitation because there was no off or reduced cycle during spray runs, and it was significantly more effective in mixing formulations in tanks with square corners.

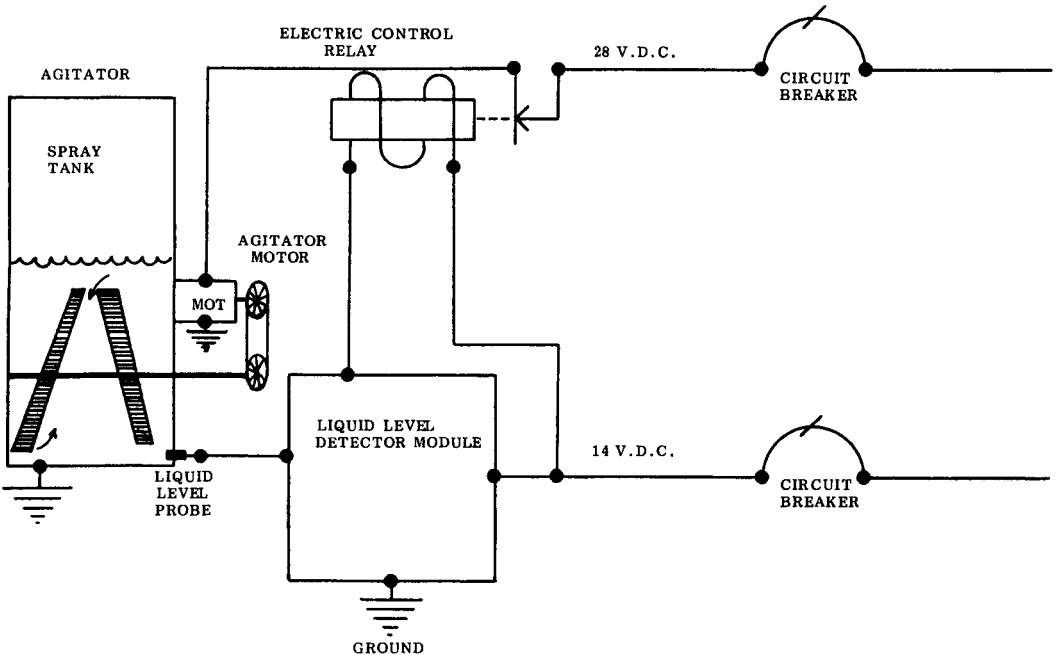

Fig. 1. Schematic representation of the automatic switching system.

controlled agitation system (Fig. 1) for a custom-made aerial spray system using Simplex components (Simplex Manufacturing Co., Portland, OR 97218) that could withstand rotary-winged aircraft vibration. This system was built specif-

The agitator consisted of four (35.5 × 4.4 cm) custom-made metal paddles, an axle (1.6 × 210 cm), two 7.6 cm pulleys and a 24-volt electric motor (Model 32A5BEPM-W2, Bodine Electric Co., Chicago, IL 60618). The agitator could not be installed into the existing aerial spray system's fiberglass spray tank; and, therefore, an aluminum 375 gal spray tank (2.24 × 1.19 × 0.54 m) of custom design was fabricated. The weight of the lighter aluminum tank was enough to completely offset the added weight of the agitator. Since our operational procedures routinely

¹ Mention of a brand name or proprietary product does not constitute a guarantee or warranty by Lee County Mosquito Control District and does not imply its approval to the exclusion of other products that may also be suitable.

require the flushing of all spray tanks after each daily use, we expected no adverse reactions between the *B.t.i.* and/or Arosurf MSF formulations and the aluminum spray tank.

The agitator must be cycled on as soon as the spray material is loaded into the tank to prevent spray system clogging, and then cycled off as soon as it is emptied to prevent axle seal wear. To facilitate this, an electrical control was incorporated with the agitator. The circuitry selected for the electrical control was an automotive low coolant indicator warning system module and low coolant probe (nos. 15591138 and 358375, respectively, Chevrolet Motor Division, Detroit, MI 48202). The electrical control consisted of a low coolant probe mounted near the bottom of the spray tank and a data processing module to determine if the probe was immersed in liquid. If the probe was not immersed, the circuitry would open a relay, turning the agitator off. The agitator was designed to stop 12 sec before the tank emptied. This was due to the probe being mounted 3 cm above the bottom of

the tank, thereby ensuring a positive off cycle. The agitator would stay off until the probe became reimmersed. The data processing module was designed to plug in and out of an edge-card connector to facilitate maintenance, if necessary. The 10 ampere load rating of the relay contacts was 100% more than the 5 ampere load of the electrical drive motor. The relay and socket (Dayton Model Nos. 1-1A484E and 5X852E, respectively, W. W. Grainger, Inc., Chicago, IL 60648) were of double-pole design, which allowed both circuits to be wired in parallel giving the motor circuit a total load rating of 20 amperes. This minimized the stress on the relay contacts. In the event of electrical control failure, a manual override switch was installed for emergency use. All circuits in the system were protected by circuit breakers.

This equipment is currently operational on a Bell UH-1 helicopter (Fig. 2) and, to date, has proven to be a reliable and effective aerial agitation system for products that are difficult to mix.



Fig. 2. Bell UH-1 helicopter equipped with aerial spray system.